

Accessories - Blowers/Fans
**FN-1282 10"
Exhaust Fan**



[Click on Image for Larger View](#)

Design Features

Fan mounts in the top of ventilated Economizer racks. Supplied with finger guard and all mounting hardware. 36" power cord supplied. Standard UL/CSA rated with 535 CFM air flow. Weight: 4.38 lbs. Heatsinking aluminum housing with high strength UL94V-0 thermoplastic impeller. Shaded-pole, thermally protected, ball bearing motor draws .70/.78 amps at 115 VAC. Operating temperature range: -20 to +60 degrees Celsius. Noise power emission level: 55 dBA.



Exhaust Fan		
Catalog Number	Drawings	Weight
FN-1282	PDF DXF	4.38

PART NAME

10" EXHAUST FAN

PART No.

FN-1282

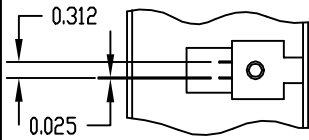

FAN

HOUSING - ALUMINUM
 STRUTS on: - DISCH
 BEARING - BALL
 VOLTAGE - 115
 FREQUENCY - 50/60
 CFM - 535
 AMPS - .78/.70
 WATTS - 51
 NPEL - 6.2
 OPERATING TEMP. RANGE: -20°C TO +60°C
 WEIGHT - 1990 GRAMS

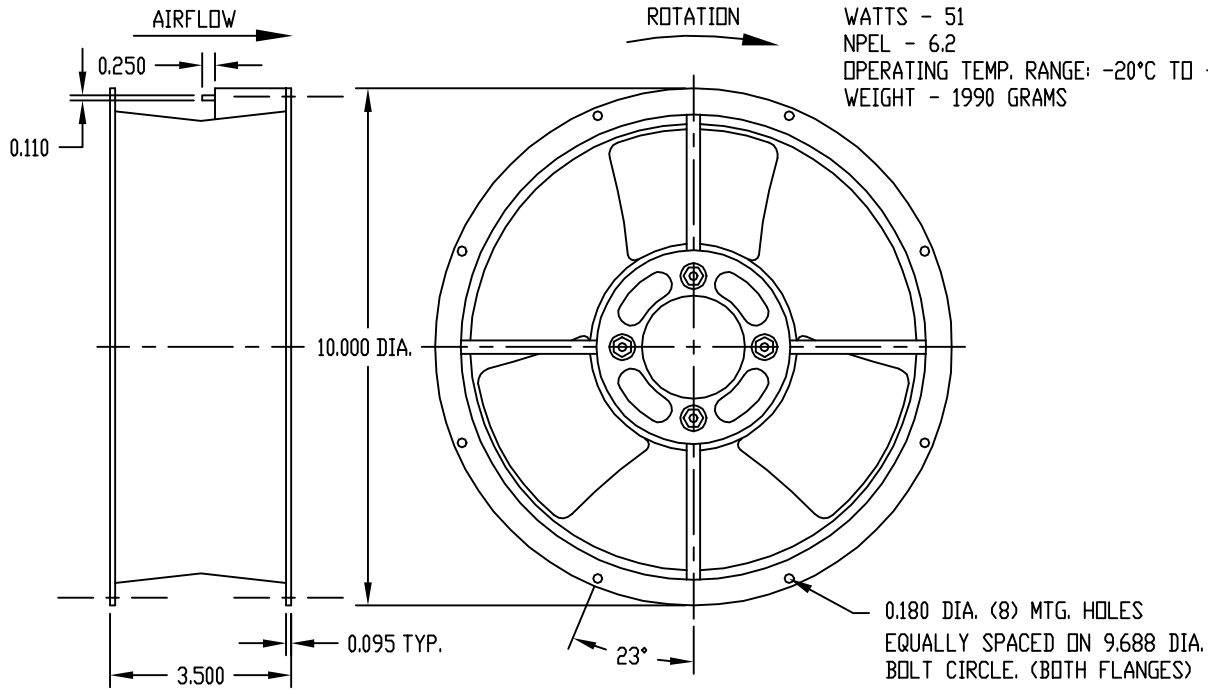

NOTE: SUPPLIED WITH ALL MOUNTING HARDWARE.

GUARD

MATERIAL: STEEL WIRE

FINISH: ZINC PLATED

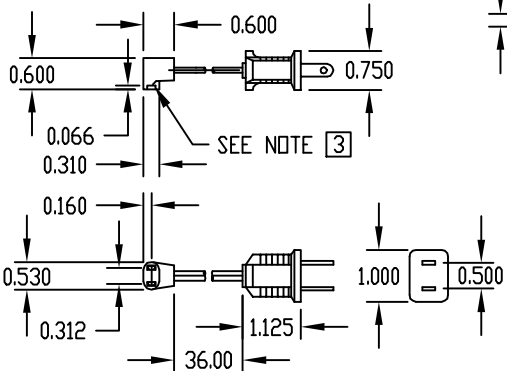
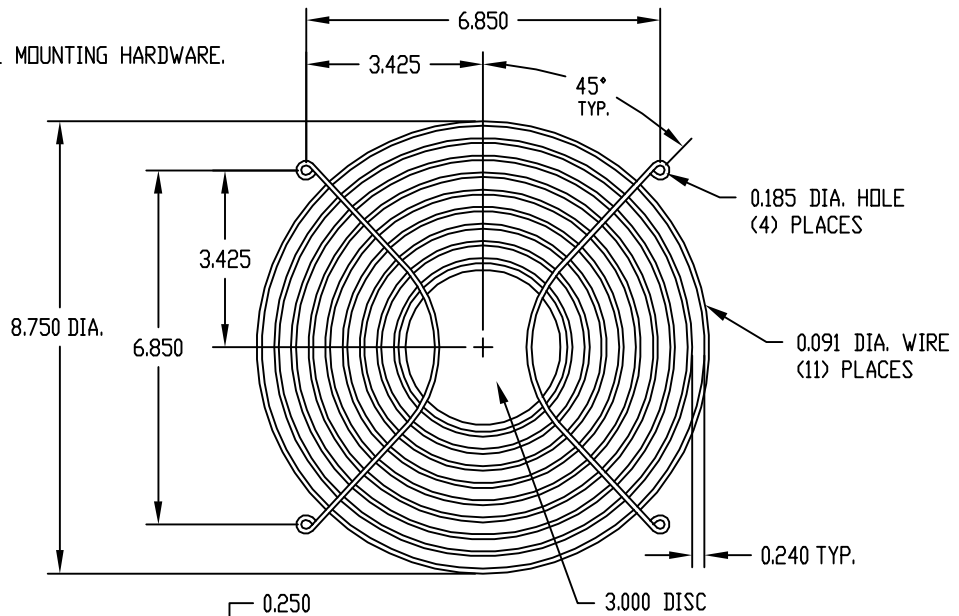

FAN CORD

- [1] MATERIAL:
 - a) LEADS-SPT-1 18AWG 105° C. INSULATION. (COLOR BLACK)
 - b) PLUG-PVC UL 105° C. (COLOR BLACK)
 - c) TERMINAL-PHOSPHOR BRONZE
- [2] UL RATED-E61080, CSA APPROVED-LR35931
- [3] TERMINALS TO BE PRE-TINNED & MUST BE FREE OF FLASH.